

SPEC SHEET SCP-12

Quote/Order# _____

Company Name: _____

Attention: _____

Email: _____

Phone#: _____

Job Name: _____

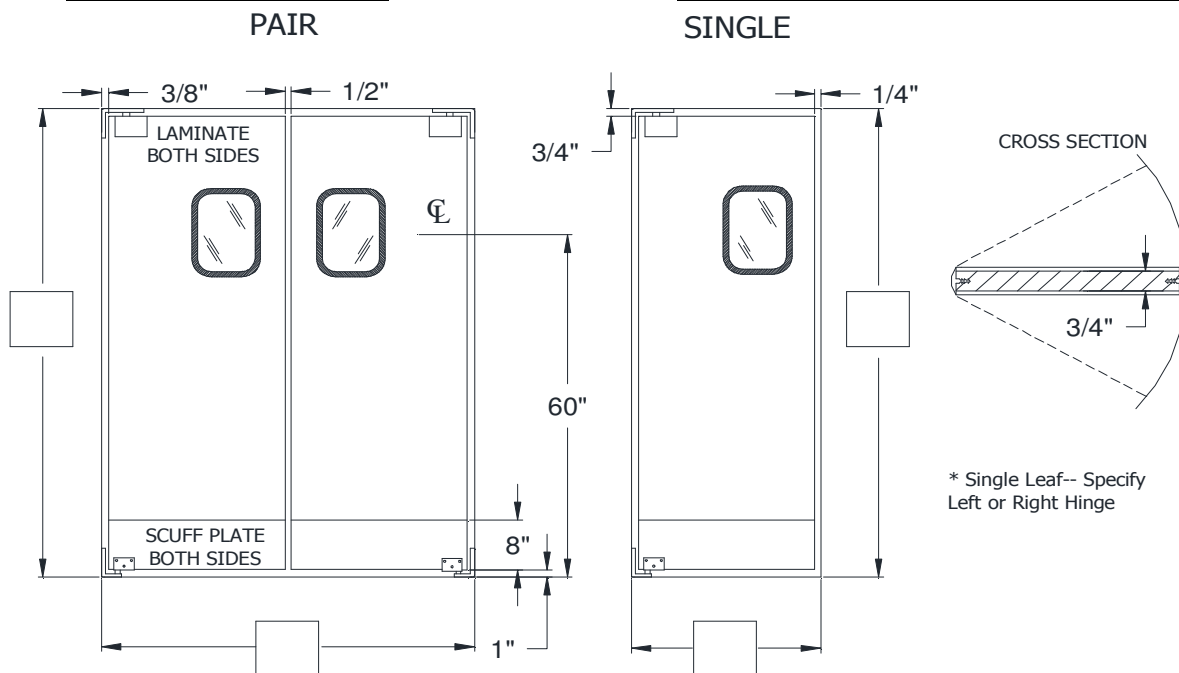

Fill in Opening Size in the Blanks Provided Above

* Single Leaf-- Specify Left or Right Hinge

STANDARD SPECIFICATIONS: Door body 3/4" exterior grade solid wood core with .032" High Pressure Laminate(HPL) both sides. 8" high black ABS scuff plate, both sides. 9" x 14" Flush window. Door assembly includes the original "NO SPRING" Easy Swing® hinges and both 1/4" - 20 x 1" thread cutting screws and #14 -1-1/2" sheet metal/wood screws for jamb by others.

INSTALLATION DETAILS: Jambs must be plumb and square. Minimum double 2 x 4 inch wood construction or equivalent. Hollow metal jambs should be reinforced at hinge locations.

SPECIFIC DETAILS FOR DOOR CONSTRUCTION:

DOOR FINISH: [] Specify Laminate: _____

JAMB GUARD: [] 3" X 9" [] 5" X 18"

WINDOW: [] Standard 9" X 14" Flush Window, Up 60" to Center of Window from Floor
 [] Other: _____

PLATE: [] Standard 8" High [] Specify Height: _____
 Color/Material: [] Black ABS [] Galvanized Steel [] Stainless Steel [] Other _____

BUMPER: Black Tear Drop Polyethylene, Height: [] 12 [] 18 [] 24 [] 30 [] 36 [] 42
 Aluminum Bumper Strip: []

OTHER SPECIFICATIONS: _____

APPROVED BY: _____

DATE: _____

Eliason Corporation